

User Guides – MODBUS protocol Firmware Version : 5601

DAT 10019

REGISTER TABLE

All the data shared by a device communicating by Modbus RTU / Modbus ASCII protocol are mapped in tables wherein to each data is associated a determined address.

Each data could be of two types:

- "REGISTER", data of 2 bytes size (word of 16 bits) that can be associated to analogue input or output, variables, set-point, etc...

- "COIL", data of 1 single bit that can be associated to digital input or output or to a logic state.

A register could contain the image (mirror) of more coils; in example the 16 digital inputs of a device could be read or written as bit (singularly) addressing the coil related to each input or can be read or written as a single word addressing the associated register wherein each bit corresponds to a coil.

In the Modbus protocol, registers and coils are divided as per the following groups of addresses:

0xxxx and 1xxxx = Coils (bit)

3xxxx and 4xxxx = Registers (word)

When read and write functions are performed, use the tables indicated below to address the registers and coils.

COILS TABLE

(*)Coil (Hex)	(*)Coil (Dec)	Description	Access
0x0001	00001	Open Detect #0	RO
0x0002	00002	Open Detect #1	RO
0x0003	00003	Open Detect #2	RO
0x0004	00004	Open Detect #3	RO
0x0005	00005	Open Detect #4	RO
0x0006	00006	Open Detect #5	RO
0x0007	00007	Open Detect #6	RO
0x0008	00008	Open Detect #7	RO
0x0009	00009	Watchdog Enable	R/W
0x000A	00010	Watchdog Event	R/W
0x000B	00011	PowerUp Event	R/W

NOTES:

(*) Subtract 1 to the address position number of the register and/or coil.

Registers and coils marked as RO in the column 'Access' are Read Only registers.

Registers and coils marked as R/W in the column 'Access' are Read and Write registers.

For the devices of DAT10000 series, the group of data 0xxxx is the mirror of the group 1xxxx, the group of data 3xxxx is the mirror of the group 4xxxx, therefore the first register could be addressed either as 30001 (with function 04) or 40001 (with function 03).

SUPPORTED MODBUS FUNCTIONS CODES

Function	Description
01	Read Coil Status (0xxxx)
02	Read Inputs Status (1xxxx)
03	Read Holding Registers (4xxxx)
04	Read Inputs Registers (3xxxx)
05	Force Single Coil
06	Preset Single Register
15 (0F)	Force Multiple Coil
16 (10)	Preset Multiple Registers

Register Position (*)	Description	Access
40001	Test	R/W
40002	Firmware [0]	RO
40003	Firmware [1]	RO
40004	Name [0]	R/W
40005	Name [1]	R/W
40006	Communication	R/W
40007	Address	R/W
40008	Delay RX/TX	R/W
40009	WatchDog timer	R/W
40010	System Flags	R/W
40011	Input type /	R/W
40012	Channel Enabling	
40015	Input # 0	RO
40016	Input # 1	RO
40017	Input # 2	RO
40018	Input # 3	RO
40019	Input # 4	RO
40020	Input # 5	RO
40021	Input # 6	RO
40022	Input # 7	RO
40023	Sync Input value # 0	RO
40024	Sync Input value # 1	RO
40025	Sync Input value # 2	RO
40026	Sync Input value # 3	RO
40027	Sync Input value # 4	RO
40028	Sync Input value # 5	RO
40029	Sync Input value # 6	RO
40030	Sync Input value # 7	RO
40031	Input Offset # 0	R/W
40032	Input Offset # 1	R/W
40033	Input Offset # 2	R/W
40034	Input Offset # 3	R/W
40035	Input Offset # 4	R/W
40036	Input Offset # 5	R/W
40037	Input Offset # 6	R/W
40038	Input Offset # 7	R/W
40039	Real Zero of Input # 0	R/W
40040	Real Span of Input # 0	R/W
40041	Scaled Physical Zero # 0	R/W
40042	Scaled Physical Span # 0	R/W
40043	Real Zero of Input # 1	R/W
40044	Real Span of Input # 1	R/W
40045	Scaled Physical Zero # 1	R/W
40046	Scaled Physical Span # 1	R/W
40047	Real Zero of Input # 2	R/W
40048	Real Span of Input # 2	R/W
40049	Scaled Physical Zero # 2	R/W
40050	Scaled Physical Span # 2	R/W
40051	Real Zero of Input # 3	R/W
40052	Real Span of Input # 3	R/W
40053	Scaled Physical Zero # 3	R/W
40054	Scaled Physical Span # 3	R/W
40055	Real Zero of Input # 4	R/W
40056	Real Span of Input # 4	R/W
40057	Scaled Physical Zero # 4	R/W
40058	Scaled Physical Span # 4	R/W
40059	Real Zero of Input # 5	R/W
40060	Real Span of Input # 5	R/W
40061	Scaled Physical Zero # 5	R/W
40062	Scaled Physical Span # 5	R/W
40063	Real Zero of Input # 6	R/W
40064	Real Span of Input # 6	R/W
40065	Scaled Physical Zero # 6	R/W
40066	Scaled Physical Span # 6	R/W
40067	Real Zero of Input # 7	R/W
40068	Real Span of Input # 7	R/W
40069	Scaled Physical Zero # 7	R/W
40070	Scaled Physical Span # 7	R/W

DESCRIPTION MODBUS REGISTERS

40001 : TEST

This register is used for the following function:
 - Synchronized Sampling (refer to section "Procedures")

40002 / 40003 : FIRMWARE

Field of 2 read only registers ; contains the firmware identifier provided by the manufactured.
 - Default value: 5601 (hex)

40004 / 40005 : NAME

Field of 2 read/write registers (4 bytes or 4 ASCII characters) available for the user, it can contain the name of the device or an abbreviation that identifies its function inside the plant. Each one of the 4 bytes could be written by values from 0 to 255, ASCII characters included.
 The default value of this field contains the identifier of the device expressed in ASCII characters.
 - Default value: "A019" (ASCII).

40006 : COMMUNICATION

If the user wants to set the communication parameters by PC, it is necessary to set the bits of this register referring to the table below in order to configure baud-rate, parity and mode. The configuration of the parameters via software is not necessary if it is done by dip switches.

- Default of manufacturer: 38400 bps, mode RTU, parity NONE

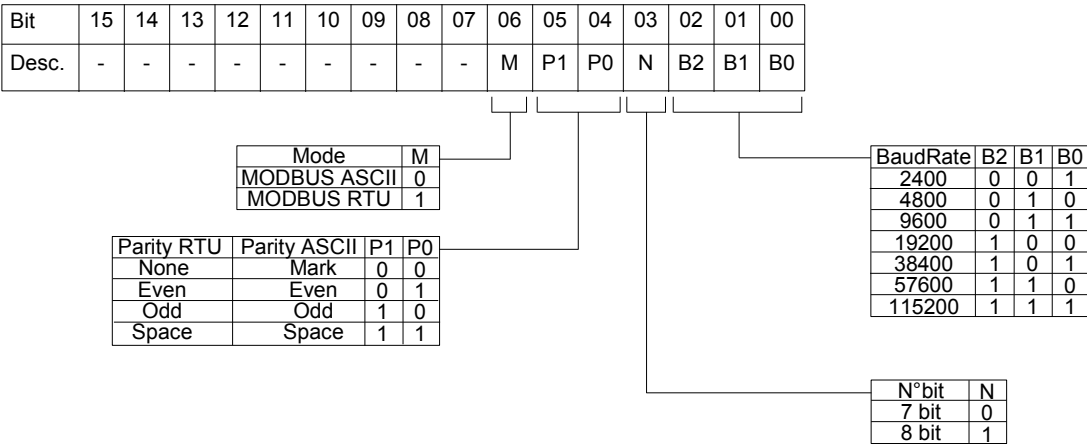

NOTE:

- the number of bits is ignored, in ASCII mode is fixed to 7; in RTU mode is fixed to 8.

40007 : ADDRESS

Contains the MODBUS address of the device; the values allowed are from 1 to 247 decimal.
 Each node connected to the same line has a unique address.
 The address 255 is used for broadcast function.
 - Default value: 01

40008 : DELAY RX/TX

Indicates the value of the delay time between the reception of a query and the transmission of the response, expressed as milliseconds.
 - Default value: 01(1 ms.)

40009 : WATCHDOG TIMER

Contains the value of WatchDog timer , expressed of intervals of 0.5 seconds. If the WatchDog is enabled and the device doesn't receive command for the time set in this register , the WatchDog Alarm will be activated (refer to section "Procedures").
 - Default value: 10 (5 sec.)

40010 : SYSTEM FLAGS

Contains the enable bits and system events of the device. The following parameters are configurable:

WATCHDOG ENABLE

Enables the WatchDog alarm. If the alarm is enabled and the device doesn't receive commands for a time higher than the one specified in register 40009, the WatchDog Alarm will be activated (refer to section "Procedures").

0 = Watchdog disabled.
 1 = Watchdog enabled.

WATCHDOG EVENT

Indicates the state of the WatchDog Alarm. If the alarm is enabled and the device doesn't receive commands for a time higher than the one specified in register 40009, this bit is forced to 1. To erase the alarm set this bit to 0. If the bit is forced to 1 by a command of the Master unit, a Watchdog event will be simulated and consequently an alarm condition will be created.

0 = Normal condition
 1 = Alarm condition

POWER-UP EVENT

This bit is forced to 1 each time the device is powered-on in order to indicated that the device has been switched-off or a reset is occurred. By the set of this bit to 0 and check its state it is possible to monitor if a reset of the device is occurred.

0 = reset not occurred
 1 = reset not occurred

COIL 00001 - 00008 : OPEN DETECT

When a sensor connected to a channel is on break condition (rupture of the sensor, cables not connected or over-temperature), the coil associated to the channel is forced to 1.

It is possible to use this register to read and write at the same time all the bits without to implement the specific functions of read and write of coils (01-02-05-15).

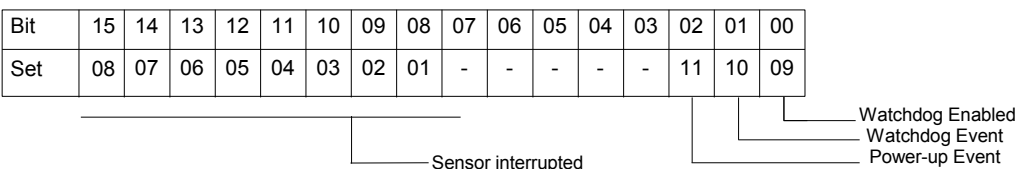

40011/40012 : INPUT TYPE / CHANNEL ENABLING

Contains the configuration of the sensor type connected to each input. The input channel could be configured independently; it is suggested to disable the channels not used.

The numeric code associated to each input type is made of 4 bit as indicated in the table beside:

- Default value: 05 (Pt100)

Insert the values of configuration (as group of 4 bits) in the register as indicated in the table below:

Bit	15	14	13	12	11	10	09	08	07	06	05	04	03	02	01	00
40011	Input Type #3				Input Type #2				Input Type #1				Input Type #0			
40012	Input Type #7				Input Type #6				Input Type #5				Input Type #4			

Value	Type
00h	Disabled
01h	500 ohm
02h	2 Kohm
05h	Pt100
06h	Ni100
07h	Pt1000
08h	Ni1000

NOTE: the channels can be differently configured with the following input types:

Group 1: Pt100 – Ni100 – 500 ohm

Group 2: Pt1000 – Ni1000 – 2000 ohm

The types of Group 1 can not be configured contemporaneously with the types of Group 2.

40015 : INPUT # 0

40016 : INPUT # 1

40017 : INPUT # 2

40018 : INPUT # 3

40019 : INPUT # 4

40020 : INPUT # 5

40021 : INPUT # 6

40022 : INPUT # 7

These registers contain the measure of each channel converted in engineering units.

The values are expressed as tenths of ohm (for resistance inputs) or tenths of °C (for RTD inputs).

The numeric format is 16 bit signed integer; the number of decimals is fixed to 1.

40023 : SYNC INPUT VALUE # 0

40024 : SYNC INPUT VALUE # 1

40025 : SYNC INPUT VALUE # 2

40026 : SYNC INPUT VALUE # 3

40027 : SYNC INPUT VALUE # 4

40028 : SYNC INPUT VALUE # 5

40029 : SYNC INPUT VALUE # 6

40030 : SYNC INPUT VALUE # 7

When the device receives the Synchronism command (refer to section "Procedures"), the input values measured in that moment and contained into the registers 40015+40022 are saved, in order of channel, into these registers.

40031 : INPUT OFFSET # 0

40032 : INPUT OFFSET # 1

40033 : INPUT OFFSET # 2

40034 : INPUT OFFSET # 3

40035 : INPUT OFFSET # 4

40036 : INPUT OFFSET # 5

40037 : INPUT OFFSET # 6

40038 : INPUT OFFSET # 7

Introduces an offset to the input measure of each channel. The value is expressed in the same format of the input registers.

40039: REAL ZERO OF INPUT #0

40040: REAL SPAN OF INPUT #0

40041: SCALED PHYSICAL ZERO #0

40042: SCALED PHYSICAL SPAN #0

40043: REAL ZERO OF INPUT #1

40044: REAL SPAN OF INPUT #1

40045: SCALED PHYSICAL ZERO #1

40046: SCALED PHYSICAL SPAN #1

40047: REAL ZERO OF INPUT #2

40048: REAL SPAN OF INPUT #2

40049: SCALED PHYSICAL ZERO #2

40050: SCALED PHYSICAL SPAN #2

40051: REAL ZERO OF INPUT #3

40052: REAL SPAN OF INPUT #3

40053: SCALED PHYSICAL ZERO #3

40054: SCALED PHYSICAL SPAN #3

40055: REAL ZERO OF INPUT #4

40056: REAL SPAN OF INPUT #4

40057: SCALED PHYSICAL ZERO #4

40058: SCALED PHYSICAL SPAN #4

40059: REAL ZERO OF INPUT #5

40060: REAL SPAN OF INPUT #5

40061: SCALED PHYSICAL ZERO #5

40062: SCALED PHYSICAL SPAN #5

40063: REAL ZERO OF INPUT #6

40064: REAL SPAN OF INPUT #6

40065: SCALED PHYSICAL ZERO #6

40066: SCALED PHYSICAL SPAN #6

40067: REAL ZERO OF INPUT #7

40068: REAL SPAN OF INPUT #7

40069: SCALED PHYSICAL ZERO #7

40070: SCALED PHYSICAL SPAN #7

Set the scaling, if desired, of the input registers (40015+40022) into the associated physical parameters.

The scaling allows to associate the configured input type values and the actual physical parameters to which is referred the input (in example for resistance associates Ω to mm).

Set the range of the sensor value measured by the device (in example for resistance 0 and 100 Ω) in the fields "Real Zero of Input" (minimum value of the input scale) and "Real Span of input" (maximum value of the input scale) associated to each channel, and set the range of the converted values (in example mm) in the fields "Scaled Physical Zero" (minimum value) and "Scaled Physical Span" (maximum value) associated to each channel.

Example:

To convert a resistance 0-100 Ω into physical parameters 100-2000 mm, set the parameters as follows:

40039 = 0 40040 = 1000 40041 = 100 40042 = 2000

The following association of values will be made in the input registers that will contain the following values :

0 Ω = "10" 50 Ω = "1050" 100 Ω = "2000"

The default value of these registers is 0 for the parameters of Zero and 1 for the parameters of Span. This in order to give the actual values of the configured input sensors and measured by the device.

PROCEDURES

USE OF "INIT" FUNCTION

The "INIT" function allows to set the device in the default configuration, independently of the software configuration made. To use this function the dip-switches must be all in OFF position.

The INIT forces: mode RTU, parity NONE, baud rate 9600, number of bit = 8, address 1

- Connect to the line RS485 only the device to configure.
- Switch-off the device.
- Connect the terminal INIT to the terminal REF.
- Power-on the device.
- Check that the green led "PWR" on the front of the device is on.

If not, check the connection of power supply (terminals V+ and V-).

- Set the communication port with the following values:
 - Mode = Modbus RTU
 - baud-rate = 9600 bps
 - parity = None
 - n° bit = 8
 - bit di stop = 1
- the device will respond to the address 01 .
- Read or write the desired settings into the registers:
 - 40006 : "Communication" to set the baud-rate.
 - 40007 : "Address" to set the address of the device.
- Switch-off the device.
- Disconnect the terminal INIT from the terminal REF.
- Power-on the device with all the dip-switches in OFF position.
- Set the communication port with the baud-rate configured in the register 40006.
- the device will respond to the address configured in the register 40007.

NOTE: the default configuration values are the following:

- Address : 01
- Baud-rate : 38400 bps
- Protocol : RTU
- Parity : None

WATCHDOG

The devices of the DAT10000 series have the Watchdog timer that, if enabled, activate an alarm each time that the communication between the device and the Master unit is not performed for a time higher that the one configured.

In alarm condition the green led PWR on the front starts to blink one time per second and is forced to 1 the coil "Watchdog Event".

To exit from the alarm condition, send a command to the device, reset the coil "Watchdog Event": the led will stop to blink.

SYNCHRONISM

The function of Synchronism is a broad-cast command sent to all the device of the net RS-485. When the devices receive this command, all the input values measured at the reception of it are saved into the proper registers.

To send the command, write the value 10 into the register "Test" (40001), to the address '255'.

NOTE: the values of synchronism are not saved in eeprom; this involves that at each power-on the values in the registers are reset.

CONFIGURATION BY DIP SWITCHES

Notice: set all the dip-switch in OFF position to access to the device in EEPROM mode (the device will follow the configuration parameters set by software) and INIT mode.

Switch-off the device before to program it by dip-switches.

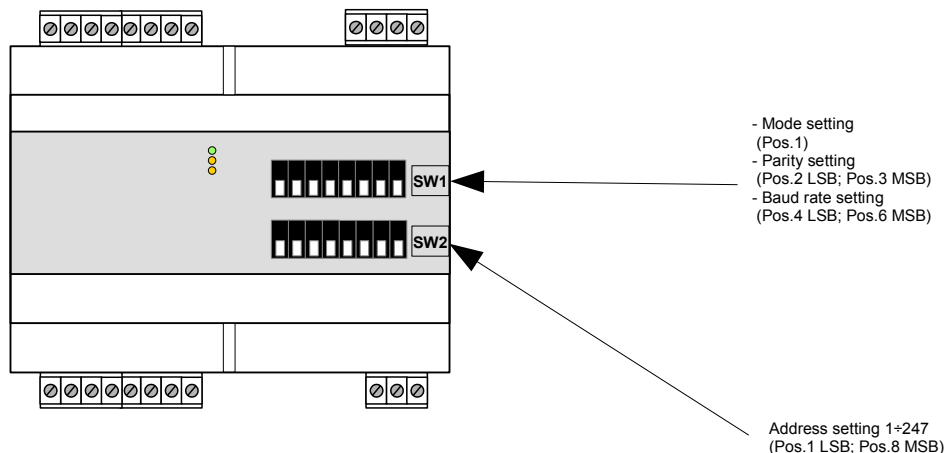

Notes (*):

- in Modbus RTU mode the setting is **NONE**; number of bit = 8
- in Modbus ASCII mode the setting is **MARK**; number of bit = 7

For the tables of configuration refer to the technical data-sheet of the device.

DIP-SWITCHES SETTING

ON OFF