

FEATURES

- **PROTECTION MODE: II 1 G Ex ia IIC T6,T5,T4 Ga** certified in according to the Directive ATEX 2014/34/EU
- **Applicable in zones with explosion risk (ZONE 0)**
- **Configurable input for RTD, mV, Resistance and Potentiometer**
- **4 ÷ 20 mA configurable output on current loop**
- **Configurable by Personal Computer, on-field reconfigurable**
- **High accuracy**
- **EMC compliant – CE mark**
- **Suitable for DIN B in-head mounting**



GENERAL DESCRIPTION

The transmitter DAT 1010 IS is able to execute many functions such as : measure and linearisation of the temperature characteristic of RTDs sensors, conversion of a linear resistance variation, conversion of a voltage signal even coming from a potentiometer connected on its input. The measured values are converted in a 4+20 mA current signal . The device guarantees high accuracy and performances stability both in time and in temperature. The programming of the DAT 1010 IS is made by a Personal Computer using the software PROSOFT, developed by DATEXEL, that runs under the operative system "Windows™". By use of PROSOFT, it is possible to configure the transmitter to interface it with the most used sensors . In case of sensors with a no-standard output characteristic, it is possible to execute, via software, a "Custom" linearisation (per step) to obtain an output linearised signal .

For Resistance and RTDs sensors it is possible to program the cable compensation with 3 or 4 wires.

It is possible to set the minimum and maximum values of input and output ranges in any point of the scale, keeping the minimum span shown in the table below. Moreover it is available the option of alarm for signal interruption (burn-out) that allows to set the output value as high or low out of scale . It is housed in a self-extinguish plastic enclosure suitable for DIN B in-head mounting.

USER INSTRUCTIONS.

The 4+20 mA output signal is measurable in the power loop as shown in the section "Output/Power supply connections"; Rload is the input impedance of instruments on the current loop; to obtain a correct measure, the value of Rload will be calculated as function of the power supply value (see section "Technical specification – Load characteristic"). The input connections must be made as shown in the section "Input connections". To configure, calibrate and install the transmitter refer to sections " DAT 1010 IS: configuration and calibration" and "Installation Instructions".

In order to guarantee a correct and safe operation of the transmitter the following requirements must be strictly satisfied

- 1) **The power supply voltage (intrinsically safe) applied between the terminals -V and +V must be included between 11 V and 30 Vdc values.**
- 2) **The maximum power supplied by the safety barrier must be not higher than 0.75 W.**

Ex Data

Output / supply	Input
Ui = 30 V Ii = 100 mA Pi = 0.75 W Li = 0.1 mH Ci = 10 nF	Uo = 6.2 V Io = 100 mA Po = 500 mW Lo = 3.6 mH Co = 5 uF
T6 : -20 + 55°C T5 : -20 + 70°C T4 : -20 + 85°C ('HT' vers.)	

TECHNICAL SPECIFICATIONS (Typical at 25 °C and in nominal conditions)

Input type	Min	Max	Min. span	Input calibration (1)	Response time (10+ 90%)	
RTD(*) 2,3,4 wires				RTD > of ±0.1% f.s. or ±0.2°C	about 400 ms	
	Pt100	-200°C	850°C	50°C		Low res. > of ±0.1% f.s. or ±0.15 Ω
	Pt1000	-200°C	200°C	50°C		High res. > of ±0.2% f.s. or ±1 Ω
	Ni100	-60°C	180°C	50°C		mV > of ±0.1% f.s. or ±18 uV
				Output calibration	Power supply	
Voltage				Current ± 7 uA	Power supply voltage 11 .. 30 Vdc	
mV	-100mV	+700mV	2 mV	Input impedance	Reverse polarity protection 60 Vdc max	
				mV >= 10 MΩ	Load characteristic - Rload (maximum load value on current loop per power supply value)	
Potentiometer				Linearity (1)		
(Nominal value)	0 Ω	200 Ω	10%	RTD ± 0.1 % f.s.		
	200 Ω	500 Ω	10%			
	0.5 KΩ	2 KΩ	10%	Line resistance influence	Temperature & humidity	
RES. 2,3,4 wires				mV <=0.8 uV/Ohm	Operative temperature -20°C .. +70°C	
Low	0 Ω	300 Ω	10 Ω	RTD 3 wires 0.05%/Ω (50 Ω balanced max.)	'HT' vers: -20°C .. +85°C	
High	0 Ω	2000 Ω	200 Ω	RTD 4 wires 0.005%/Ω (100 Ω balanced max.)	Storage temperature -40°C .. +85°C	
				RTD excitation current	Humidity (not condensed) 0 .. 90 %	
Output type	Min	Max	Min. span	Typical 0.350 mA	Housing	
Direct current	4 mA	20 mA	4 mA	Thermal drift (1)	Material Self-extinguish plastic	
Reverse current	20 mA	4 mA	4 mA	Full scale ± 0.01% / °C	Mounting DIN B head or bigger	
				Burn-out values	Weight about 50 g.	
				Max. value about 22.5 mA	Dimensions Ø = 43 mm ; H = 24 mm	
				Min. value about 3.6 mA	EMC (for industrial environments)	
				(1) referred to input Span (difference between max. and min. values)	Immunity EN 61000-6-2	
					Emission EN 61000-6-4	

(*) For temperature sensors it is possible to set the input range also in F degrees; to made the conversion use the formula: °F = (°C*9/5)+32)

DAT 1010 IS: CONFIGURATION AND CALIBRATION

Warning: during these operations the device must always be powered by a safety barrier; to connect the interface Prodat, use the protection cable CVPR-03.

- CONFIGURATION

- 1) Power-on the DAT 1010 IS by a safety barrier (see Ex data) .
- 2) Remove the protection plastic cap on DAT 1010 IS.
- 3) Connect the interface PRODAT to the Personal Computer and to device, using the protection cable CVPR-03. (see section "DAT 1010 IS: PROGRAMMING").
- 4) Run the software PROSOFT.
- 5) Set the parameters of configuration .
- 6) Program the device.

- CALIBRATION CONTROL

With software PROSOFT running:

- 1) Connect on the input a calibrator setted with minimum and maximum values referred to the electric signal or to the temperature sensor to measure.
- 2) Set the calibrator at the minimum value.
- 3) Verify that the DAT 1010 IS provides on output the minimum setted value.
- 4) Set the calibrator at the maximum value.
- 5) Verify that the DAT 1010 IS provides on output the maximum setted value.
- 6) In case of regulation of value obtained in the step 3 and 5, use the ZERO and SPAN regulators of software PROSOFT. The variation introduced from these regulators must be calculated as percentage of the input range .
- 7) Program the device with the new parameters .

DAT 1010 IS: PROGRAMMING

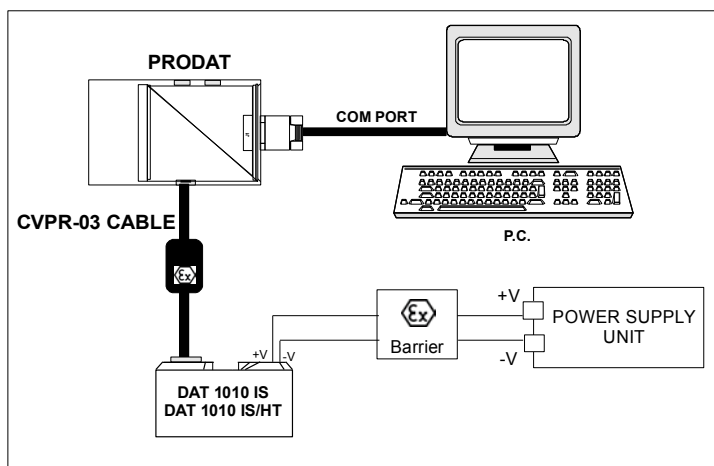

DIN B in-head mounting

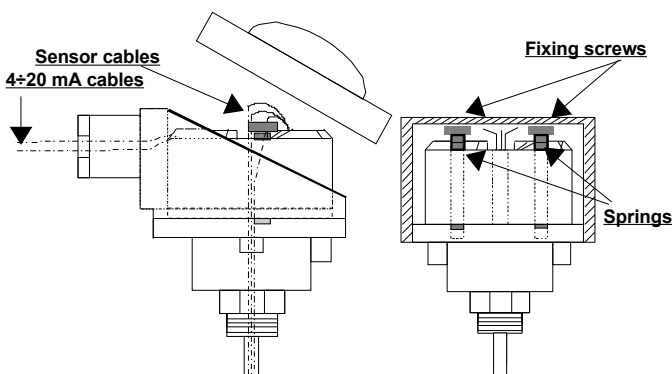

DIN rail mounting (Optional)

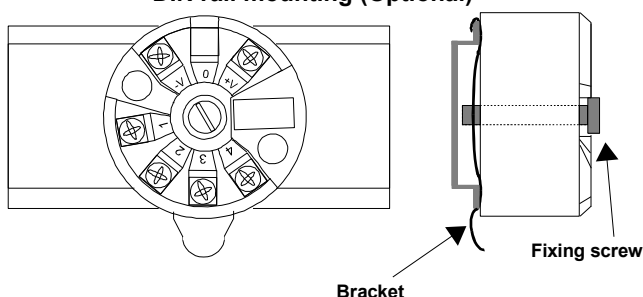

INSTALLATION INSTRUCTIONS

In order to guarantee the safety requirements, before to install the device, refer to the "Safety Instructions" provided with the device.

The transmitter must be mounted in order to guarantee to it an IP54 protection grade or more for external environments and an IP4X protection grade or more for internal environments or protected area.

The device DAT 1010 IS is suitable for direct DIN B in-head mounting. The transmitter must be fixed inside the probe by the proper kit.

Using the bracket, provided on request, it is possible to install the device on the DIN 50022 rail.

It is necessary to install the device in a place without vibrations; avoid to routing conductors near power signal cables.

The protection enclosure type for DAT 1010 IS must be selected according to the installation Zone:

- **Zone 0:** enclosure exclusively in stainless;

- **Zone 1 or 2:** enclosure in aluminium or plastic; if plastic, apply on the enclosure the following warning:

"Electrostatic discharge: Clean only with a damp cloth or anti-static products."

DAT 1010 IS: CONNECTIONS

INPUT CONNECTIONS

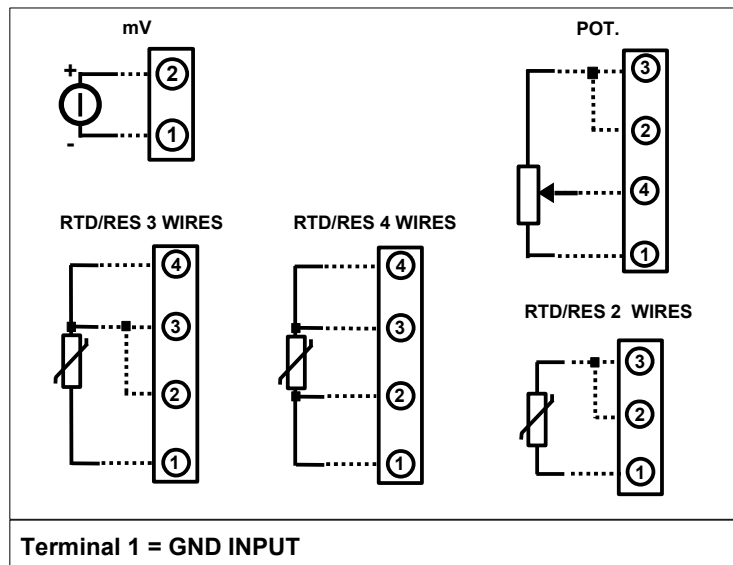

OUTPUT/POWER SUPPLY CONNECTIONS

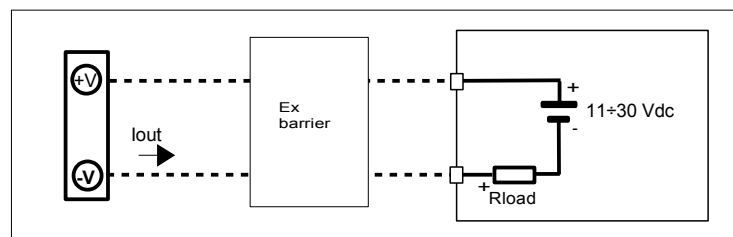

MECHANICAL DIMENSIONS (mm)

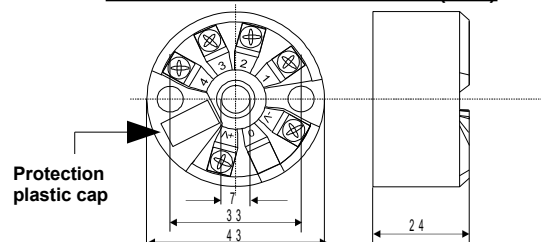

HOW TO ORDER

The DAT 1010 IS is provided as requested on the Customer's order. Refer to the section "Technical specification" to determine input and output ranges. In case of the configuration is not specified, the parameters must be set by the user. Please refer to the "Technical Specifications" section for available input and output ranges. The DIN rail bracket must be requested with the code DIN RAIL.

ORDER CODE EXAMPLE:

