

## FEATURES

- Acquisition of analogue signals on PLC's digital I/O
- Analogue input to any PLC or micro PLC
- Up to 16-bit resolution with Full Scale high accuracy
- 2 input channels
- Configurable input for  $\pm 10$  V and  $\pm 20$  mA
- Configurable by DIP-switch
- Galvanic isolation at 2000 Vac on three ways
- EMC compliant – CE mark
- Suitable for DIN rail mounting in compliance with EN 50022 and EN-50035



## GENERAL DESCRIPTION

The device DAT6013 is designed to measure, amplify and linearise two analogue signals coming from sensors with voltage output (up to  $\pm 10$  V) or current output (up to  $\pm 20$  mA ) in a 16 bits resolution digital words that contain the input values. The digital signal is transferred to PLC by one of its digital inputs. The data transfer must be controlled by the PLC by the generation of a clock signal over one of its digital ports.

It is housed in a plastic enclosure of 12.5 mm thickness suitable for DIN rail mounting in compliance with EN-50022 and EN-50035 standards.

## USER INSTRUCTIONS

**Before to install the device, read carefully the section "Installation instructions"**

Connect the power supply, the PLC and the analogue inputs as shown in the section "Wiring".

If necessary, configure the devices by dip-switch on the side of the device as shown in the section "Configuration"

I LED "PWR" and "DATA" indicates the status of the device: refer to the section "Light Signalling" to verify the device working.

## DATA ACQUISITION PROCEDURE (example in the picture)

To get data from the device, the PLC must generate an enabling signal (ENABLE) and a clock (CLK) to the proper device's terminals. If the enable is high, at each rise edge of the clock signal, the device provides on the data line (DATA) one of the bit of reading. Each word is built of 1 synchronism bit followed from 16 bit for each analogue input. Each word has 33 bits length. The rise edge of the ENABLE signal allow the reset of reading cycle.

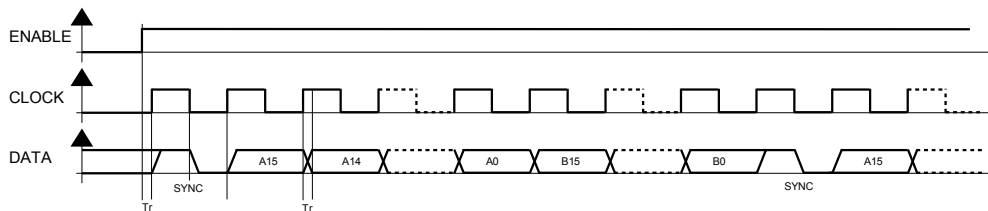

## TECHNICAL SPECIFICATIONS (Typical at 25 °C and in nominal conditions)

Input type	Min	Max	ANALOG INPUT		POWER SUPPLY	
<b>Voltage</b> 10 V	- 10 V	+ 10 V	<b>Thermal drift (1)</b> Full Scale	$\pm 0.005 \% / ^\circ\text{C}$	Supply voltage	18 .. 30 Vdc
<b>Current</b> 20 mA	- 20 mA	+ 20 mA	<b>Input impedance</b> V mA	$\geq 100$ Kohm $\leq 50$ ohm	Current consumption	30 mA @ 24 Vdc
<b>Input channels:</b>	2		<b>Warm-up time</b>	3 minutes	Reverse polarity protection	60 Vdc max
<b>Input calibration (1)</b>	$\pm 0.1\% \text{ f.s.}$		<b>Sampling time</b>	$\sim 0.3 \text{ sec.}$	Max. current consumption	45 mA
<b>Linearity (1)</b>	$\pm 0.1\% \text{ f.s.}$		<b>DIGITAL INTERFACE</b>		<b>ISOLATION</b>	
			<b>Voltage on terminals</b>	typical 24 Vdc ( 30 Vdc max.) > 9 Vdc	Inputs – PLC	2000 Vac 50 Hz, 1 min.
			ON state		Power supply – Inputs	2000 Vac 50 Hz, 1 min.
			<b>Input impedance</b> (ENABLE, CLK)	4.7 KOhm	Power supply – PLC	2000 Vac 50 Hz, 1 min.
			<b>Minimum output load</b> (DATA)	560 Ohm (2)	<b>ENVIRONMENTAL CONDITIONS</b>	
			<b>Max. clock signal frequency</b>	500 Hz	Operative Temperature	-10°C .. +60°C
			<b>Rise / Fall time (Tr)</b>	<0.2 ms	Storage Temperature	-40°C.. +85°C
					Humidity (not condensed)	0 .. 90 %
					Maximum Altitude	2000 m
					Installation	Indoor
					Category of installation	II
					Pollution Degree	2
					<b>MECHANICAL SPECIFICATIONS</b>	
					Material	Self-extinguish plastic
					IP Code	IP20
					Wiring	wires with diameter 0.8±2.1 mm <sup>2</sup> /AWG 14-18
					Tightening Torque	0.8 N m
					Mounting	in compliance with DIN rail standard EN-50022 and EN-50035
					Weight	about 50 g.
					<b>EMC ( for industrial environments )</b>	
					Immunity	EN 61000-6-2
					Emission	EN 61000-6-4

(1) referred to input Span (difference between max. and min. values)

(2) The load on the output DATA is controlled with the current taken from the ENABLE signal

## INSTALLATION INSTRUCTIONS

The DAT 6013 device is suitable for fitting to DIN rails in the vertical position.

For optimum operation and long life follow these instructions:

**When the devices are installed side by side it may be necessary to separate them by at least 5 mm in the following case:**

- If panel temperature exceeds 45°C device powered by an high power supply voltage: > 27 Vdc.

Make sure that sufficient air flow is provided for the device avoiding to place raceways or other objects which could obstruct the ventilation slits. Moreover it is suggested to avoid that devices are mounted above appliances generating heat; their ideal place should be in the lower part of the panel.

Install the device in a place without vibrations.

Moreover it is suggested to avoid routing conductors near power signal cables (motors, induction ovens, inverters, etc...) and to use shielded cable for connecting signals.

## CABLING

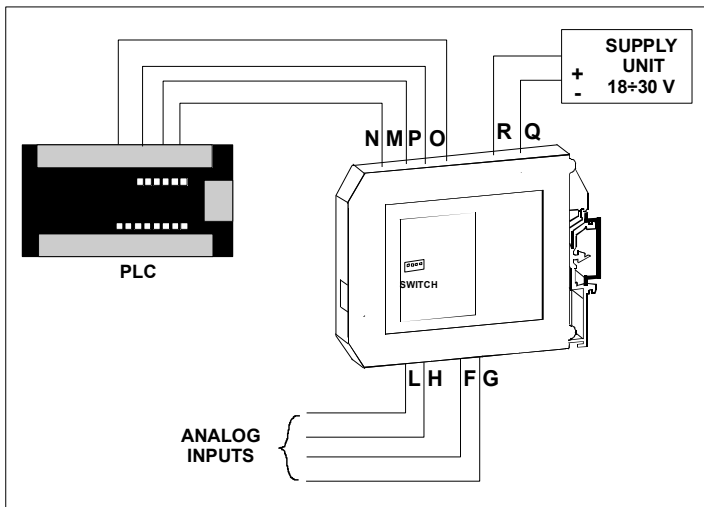

## PROGRAMMING TABLE

SW4	Filter (CLK)	SW3	SW2	SW1	Input
	1 ms (500 Hz)				10 V
●	10 ms (50 Hz)			●	20 mA
		●			---
		●	●	●	---
●				●	---
●		●		●	---
●		●	●	●	---
●		●	●	●	---

● = Switch ON

## DIMENSIONS (mm)

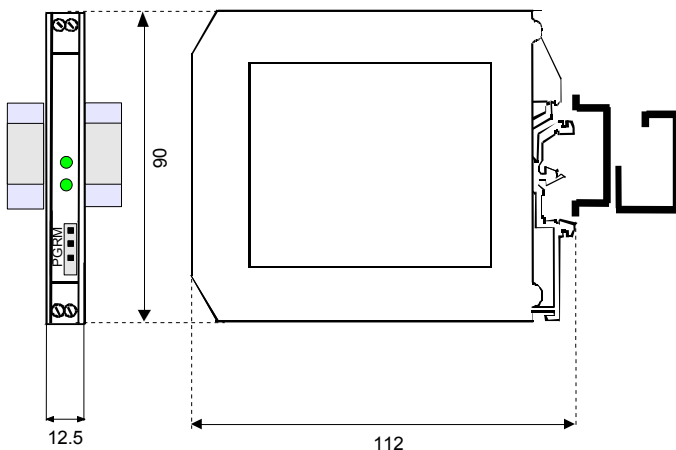

## WIRING

### ANALOG INPUTS CONNECTIONS

#### VOLTAGE

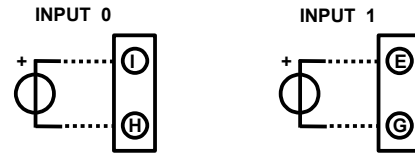

#### CURRENT

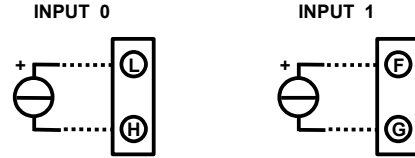

NOTE: the input channel are not isolated between them (H-G) = Ref.

### PLC CONNECTION

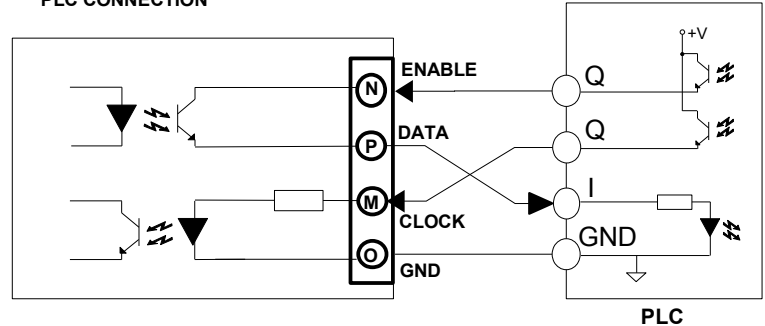

### POWER SUPPLY CONNECTIONS

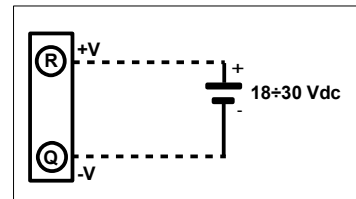

### ISOLATION STRUCTURE

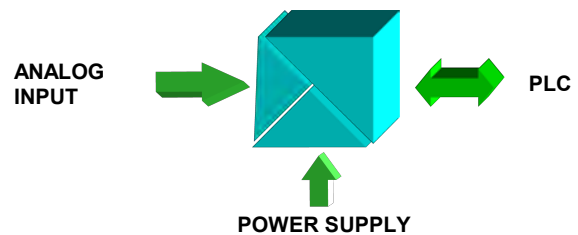

### LIGHT SIGNALLING

LED	COLOUR	STATE	DESCRIPTION
PWR	GREEN	ON	Device powered
		OFF	Device not powered
DATA	GREEN	ON	"DATA" Line = 1
		OFF	"DATA" Line = 0

### HOW TO ORDER

In phase of order it is necessary to specify the type of table for the input. The DAT 6013 is supplied as requested from the Customer. Refer to the section "Programming table" for the available options

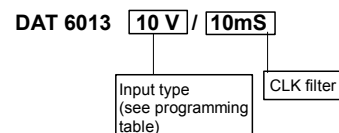

■ = Requested  
□ = Optional