



User Guide – MODBUS protocol Firmware Version : 3300

DAT 3018

PRELIMINAR DESCRIPTION

All the data variables shared by a Modbus module are shown in tables, where each data is linked to one address. Each data can be of two types:

- “COIL”, composed by a single bit, can be associated to digital input (switch), digital outputs (relays), logic states (alarms).
- “REGISTER”, composed by 2 bytes (16 bits), can be associated to analog input or outputs, variables, set-point, etc...

A register can also include the image of more coils, for example the 16 digital inputs of a device can be read and write as bit, one by one, addressing the relative coil , or they can be read or write as a single 16-bit port addressing the associated register, where for example the last significant bit will respond to the first coil.

In the Modbus protocol, coils and registers are divided in banks:
0xxxx and 1xxxx = Coils (bits)
3xxxx and 4xxxx = Registers (words)

REGISTERS TABLE

| Register | Description | Access | E ² P |
|----------|-----------------------|--------|------------------|
| 40001 | Test | R/W | |
| 40002 | Firmware Version | R | |
| 40003 | | R | |
| 40004 | Device Name | R/W | * |
| 40005 | | R/W | * |
| 40006 | Communication | R/W | * |
| 40007 | Address | R/W | * |
| 40008 | RX/TX Delay | R/W | * |
| 40009 | Watchdog Timer | R/W | * |
| 40010 | Coils | R/W | |
| 40011 | Input Type | R/W | * |
| 40012 | Channel Enable | R/W | * |
| 40013 | CJC Offset | R/W | * |
| 40014 | CJC Value | R | |
| 40015 | Input # 0 | R | |
| 40016 | Input # 1 | R | |
| 40017 | Input # 2 | R | |
| 40018 | Input # 3 | R | |
| 40019 | Input # 4 | R | |
| 40020 | Input # 5 | R | |
| 40021 | Input # 6 | R | |
| 40022 | Input # 7 | R | |
| 40023 | Sync. value input # 0 | R | |
| 40024 | Sync. value input # 1 | R | |
| 40025 | Sync. value input # 2 | R | |
| 40026 | Sync. value input # 3 | R | |
| 40027 | Sync. value input # 4 | R | |
| 40028 | Sync. value input # 5 | R | |
| 40029 | Sync. value input # 6 | R | |
| 40030 | Sync. value input # 7 | R | |

NOTE:

The registers marked with ' * ' in the ' E²P ' column are saved in EEPROM each time they are written, to be automatically reloaded to each power-on of the device.

COILS TABLE

| Coil | Description | Access | E ² P |
|-------|-----------------|--------|------------------|
| 00001 | Open Detect #0 | R | |
| 00002 | Open Detect #1 | R | |
| 00003 | Open Detect #2 | R | |
| 00004 | Open Detect #3 | R | |
| 00005 | Open Detect #4 | R | |
| 00006 | Open Detect #5 | R | |
| 00007 | Open Detect #6 | R | |
| 00008 | Open Detect #7 | R | |
| 00009 | Watchdog Enable | R/W | |
| 00010 | Watchdog Event | R/W | |
| 00011 | Power Up Event | R/W | |

IMPLEMENTED MODBUS FUNCTIONS

| Function | Description |
|----------|--------------------------------------|
| 01 | Read multiple coils (0xxxx bank) |
| 02 | Read multiple coils (1xxxx bank) |
| 03 | Read multiple registers (4xxxx bank) |
| 04 | Read multiple registers (3xxxx bank) |
| 05 | Write single coil |
| 06 | Write single register |
| 15 | Write multiple coils |
| 16 | Write multiple registers |
| 08 | Diagnostic |

NOTE:

For DAT3000 series devices, the bank 0xxxx is a mirror of bank 1xxxx, as the 3xxxx bank is a mirror of bank 4xxxx, as for i.e. the first register can be read indifferently as 30001 (with the function 04) or 40001 (with the function 03)

REGISTER DESCRIPTION

40001 : TEST

This register is used to perform the following functions:
 - Analog inputs calibration (see the "Procedures" section).
 - Synchronized sampling (see the "Procedures" section).

40002 / 40003 : FIRMWARE VERSION

Read-only 2-register field, that hold the manufacturer firmware identifier.
 - Manufacturer default: 3300 (hex)

40004 / 40005 : DEVICE NAME

2-registers field (4 byte or 4 ASCII characters) user free, that can hold the device name or a function identifier. Each byte can be written with each value from 0 to 255, than ASCII characters too.
 - Manufacturer default: "3018" (ASCII).

40006 : COMMUNICATION

Set the bits of this register as shown in the following table, to set the baud-rate, the bit number, the parity type and the protocol type.
 - Manufacturer default: 38400 bps, RTU mode

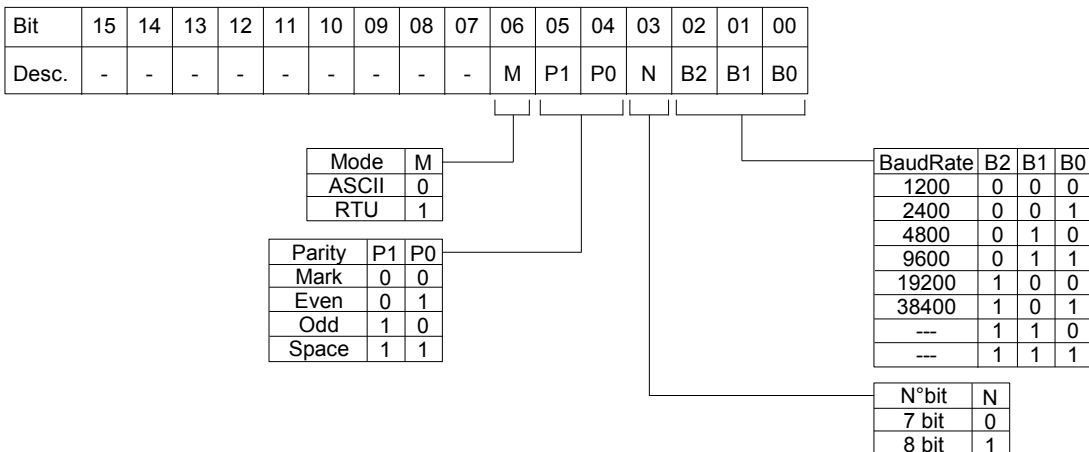

NOTES:

- the bit number is ignored, as for in ASCII mode it is fixed to 7 and in RTU mode it is fixed to 8.
- In RTU mode the parity is ignored (parity NONE)

40007 : ADDRESS

Specify the net address of the device; there are allowed the address from 1 to 255.
 Each device connected to the same net must have a unique address.
 The address 255 is used for broadcast functions (i.e. synchronized sampling)
 - Manufacturer default: 01

40008 : RX/TX DELAY

Specify the value of the delay between the reception of a command and the response transmission, indicated in milliseconds.
 - Manufacturer default: 1 (1 ms.)

40009 : WATCHDOG TIMER

Specify the value of the WatchDog Timer (see the "Procedures" section), indicated in steps of 0.5 seconds.
 - Manufacturer default: 10 (5 sec.)

40010 : COILS

This register is a mirror of the coils table: each bit of this register corresponds to a coil, as shown in the following table.

| Bit | 15 | 14 | 13 | 12 | 11 | 10 | 09 | 08 | 07 | 06 | 05 | 04 | 03 | 02 | 01 | 00 |
|------|----|----|----|----|----|----|----|----|----|----|----|----|----|----|----|----|
| Coil | 08 | 07 | 06 | 05 | 04 | 03 | 02 | 01 | - | - | - | - | - | 11 | 10 | 09 |

40011 : INPUT TYPE CONFIGURATION

Specify the sensor type connected to the inputs. All channels have the same configuration.
 Insert the values indicated in the table.
 - Manufacturer default: 01h (50mV)

| Value | Type |
|-------|-----------|
| 01h | ± 50 mV |
| 02h | ± 100 mV |
| 03h | ± 250 mV |
| 04h | ± 1000 mV |
| 0Eh | Tc J |
| 0Fh | Tc K |
| 10h | Tc T |
| 11h | Tc E |
| 12h | Tc R |
| 13h | Tc S |
| 14h | Tc B |
| 15h | Tc N |

40013 : CJC OFFSET

Offset calibration value of the cold junction measure for thermocouples. The value is expressed in hundreds of degrees.

40014 : CJC VALUE

Thermocouple cold junction measure. The value is expressed in hundreds of degrees.

40015 : INPUT VALUE # 0**40016 : INPUT VALUE # 1****40017 : INPUT VALUE # 2****40018 : INPUT VALUE # 3****40019 : INPUT VALUE # 4****40020 : INPUT VALUE # 5****40021 : INPUT VALUE # 6****40022 : INPUT VALUE # 7**

| Type | Decimals |
|--------------|----------|
| ± 50 mV | 2 |
| ± 100 mV | 2 |
| ± 250 mV | 2 |
| ± 1000 mV | 1 |
| Thermocouple | 1 |

These registers contain the measure value for each input channel, converted in engineering units: the values are expressed in mV (for voltage inputs) or °C (for thermocouple inputs). The format is a 16bit signed integer; the decimal number depends from the input type, as shown in the table.

40023 : SYNCHRONISM INPUT VALUE # 0**40024 : SYNCHRONISM INPUT VALUE # 1****40025 : SYNCHRONISM INPUT VALUE # 2****40026 : SYNCHRONISM INPUT VALUE # 3****40027 : SYNCHRONISM INPUT VALUE # 4****40028 : SYNCHRONISM INPUT VALUE # 5****40029 : SYNCHRONISM INPUT VALUE # 6****40030 : SYNCHRONISM INPUT VALUE # 7**

When the device receive the Sync command (see the "Procedures" section), the actual input values in the 40015-40018 registers are saved in these registers, channel by channel, to be read in a following time.

COILS DESCRIPTION

00001 / 00008 : OPEN DETECT

When the sensor connected to one channel goes in break condition (sensor damage, unconnected wire or out-range), the corresponding coil is forced to 1.

00009 : WATCHDOG ALARM ENABLE

Enable the WatchDog alarm. If the alarm is enabled and the device does not receive any command for a time longer than the time specified in the 40009 register, the WatchDog alarm Event coil is forced to 1 (see the "Procedures" section).

0 = Watchdog alarm disabled
1 = Watchdog alarm enabled

00010 : WATCHDOG ALARM EVENT

This coil indicates the condition of WatchDog Alarm. If the alarm is enabled and the device does not receive any command for a time longer than the time specified in the 40009 register, this coil is forced to 1. To return from the alarm condition, set this coil to 0.

0 = Normal Condition
1 = Alarm Condition

00011 : POWER-UP EVENT

This coil is forced to 1 at each power-on of the device; this state indicates that the device has been switched off. It is possible to know if a reset of the device is happened clearing this coil and monitoring its state.

0 = reset not happened
1 = reset happened

PROCEDURES

HOW TO USE THE "INIT" FUNCTION

If the exact configuration of a module is unknown, it can result impossible to establish a communication with it. The "INIT" function gives a solution to this throuble:

- Connect to the RS485 net only the device to configure.
- Turn off the device.
- Connect the INIT pin (D) to the GND pin (C).
- Turn on the device.
- Ensures that the "PWR" green LED on the front of the enclosure is lighted.

If not, control the voltage supply connections (I and J pins) and RS485 net connections (A and B pins). If the supply connection is right, and the led still unlighted, it can be necessary to invert the RS485 pins connection.

- Set the communication port to these values:
 - baud-rate = 9600 bps
 - parity = None
 - n° bits = 8
 - stop bits = 1
- The device now communicates at the address 01 with the RTU protocol.
- Read or program the desired settings on the registers:
 - 40006 : "Communication" for the baud-rate setting
 - 40007 : "Address" for the net address of the device
- Turn off the device.
- Disconnect the INIT pin from the GND pin.
- Turn on the device.
- Set the communication port at the baud-rate programmed in the 40006 register.
- The device now communicates with the addressprogrammed in the 40007 register.

NOTE: The default manufacturer programmation is the following:

- Address : 01
- Baud-rate : 38400 bps
- Protocol : RTU

WATCHDOG

The modules has been provided of a Host Watchdog timer which, when it is enabled, makes to start the alarm each time the communication between the module and the host is inactive for a period time greater then the programmed one. When the alarm goes on, the values of the outputs are automatically converted to the values set as 'safety value', that corresponding to the state in which the outputs must be putted, and therefore the actuators are putted, to avoid damages to the system in case of failure. Moreover, under the alarm condition the green LED on the front of the enclosure is blinking and the "Watchdog Event" coil is forced to 1.

To return from the alarm condition, reset the coil "Watchdog Event" coil: the LED stop blinking and it is possible to set the outputs.

There is also a Module Watchdog timer that monitor the internal CPU work and is active when the CPU don't function correctly for any reason, and resets the module. After the reset, all outputs will assume their initial default value ("power up value"), that may be different to the output value after the reset.

SYNCHRONISM

The Synchronism function is performed by a command sent to all devices connected on the net. When the devices receive the Sync command, all input states are saved in the relative register, to be read after time. Doing this, it is possible to read the value of all inputs at the Sync command time. To send the synchronism command, write the value 10 in the "Test" register (40001) at the address 255.

NOTE: The sync values are not saved in EPROM.

CALIBRATION

The procedure of calibration is performed in factory on all the modules during the testing phase. However it can be convenient to make another calibration of the module according to the requirements of the user. To make this, it is necessary to use precision instruments and to correctly perform all the necessary steps, because any error reduces the accuracy and the good operation of the device.

NOTA: Per la misura delle termocoppie, il modulo si basa sulla taratura dell'ingresso ± 50 mV.

NOTE: For the Thermocouple measure, the device uses the calibration of ± 50 mV input type.

To re-calibrate the device, follow this procedure:

- 1 – Turn on the device in INIT condition
- 2 – Conncet a calibrator to the channel #0.
- 3 – Program the input type to be calibrated
- 4 – Set the calibrator at 0 mV.
- 5 – Write on the "Test" register (40001) the value 20.
- 6 – Set the calibrator to the full-scale value (50mV, 100mV, 250 mV or 1000 mV)
- 7 – Write on the "Test" register (40001) the value 30.
- 8 – Repeat point 3 to 7 for each input type to be calibrated.